

USE INSTRUCTIONS

Banho-Maria

PNH

BM02/0

SYMBOLS USED IN THIS MANUAL



Read the instructions before using the appliance.



Important safety instructions. Risk of imminent accident if not observed



Practical notice for the user.



Instructions for duly qualified persons only.

1. Safety and proper use

1.1. Security instructions

The equipment is safe to use and complies with current European safety requirements. However, improper use can lead to personal injury and property damage. To ensure proper and safe operation, read this manual before operating the equipment. This manual contains important warnings about the installation, safety, use and care of the equipment.

Save this manual for future reference. Provide the manual with the equipment to a new owner of the equipment.

The manufacturer cannot be held liable for damages resulting from improper or incorrect use. Please note that the instructions in this manual do not replace the technical specifications recorded on the rating plate on the equipment.



Read the safety instructions carefully!



Before using the equipment, check that there are no visible damages. Never use damaged equipment



Connect the equipment to a grounded electrical circuit. The electrical safety of the equipment is only guaranteed if it has a correct connection.



This equipment is supplied with an equipotential bonding terminal on the back, which must be properly connected to the ground circuit by an authorized installer.



Do not connect the equipment to the power source with a multiple plug or an extension cord. These do not guarantee the safety of the equipment



The installation and repair operations must comply strictly with the local and national safety regulations in force.



Keep the equipment clean at all times.



Risk of scalding! Do not touch the inside surfaces of the tub while they are hot.



Risk of scalding! Do not open the water drain valve while it is warm.



Never use the equipment with the water level below the minimum mark (MIN), otherwise the equipment may be damaged.



Only qualified and accredited personnel may install and repair the equipment. The manufacturer is not liable for damages resulting from repairs and other interventions by unqualified persons

1.2. Purpose of use

The Banho-Maria PNH was developed to allow the conservation of food through indirect heating.

The manufacturer does not advise any other use, as this may be dangerous.

1.3. User requirements

The equipment should be kept out of the reach of children and should be supervised to ensure they do not play with the equipment.

1.4. Recycling

Treatment of packaging material: Before using the equipment for the first time, remove the protective plastics from stainless steel. Recycle shipping carton and all protective materials.



Check for safe disposal of all plastic packaging. Keep plastic containers out of the reach of children.
Danger of suffocation!



Electrical and electronic equipment contain materials that, when improperly handled, endanger human health and the environment. Do not dispose of any part or component of the equipment in household waste; place them in collection / recycling centres or contact your supplier or local authorities for advice.

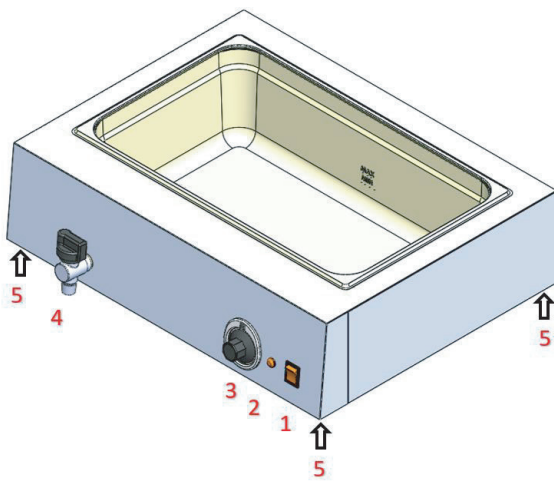

2.1. Technical specifications

Banho-Maria G.N. 1/1 L450

- 1. Waterproof main switch
- 2. Heating indicator
- 3. Heating thermostat 0-85°C
- 4. Faucet for water discharge

2. Description

5. Levelling Feet

Model	Product Dim. LxPxA (mm)	Size/nº maximum of Buckets	Water capacity (lts)	Gross weigh t (Kg)	Net weigh t (Kg)	Potency (W)	Tens. (V/Hz)	Packing Dim. LxPxA (mm)
Banho-Maria GN 1/1 L450	600x455x182	2xGN 1/2 100 3xGN 1/3 100 6xGN 1/6 100	6	9,3	8,1	800W	230/50Hz	650x525x310

NOTE: Gastronome buckets not included (sold separately).

2.2. Required links

Electrical connection with protective earthing

Equipotential bonding to protective earth

2.3. Usage location

Use on solid workbench or table.

Choose a dry place where the equipment cannot come into direct contact with water.



Never direct jets of water to the equipment.

Place the equipment on a stable, level surface.

This appliance may be used by children 8 years of age or older and persons whose physical, sensory or mental capacities are reduced, or by persons without experience or knowledge if they have been given supervision or instructions regarding the use of the appliance in a and understood the hazards involved



Children should not play with the appliance.

2.4. Unpacking

Remove all protective material from the packaging. Check the equipment.

Remove the protective plastics from stainless steel. Clean the outside of the machine with a damp cloth.

Dispose of the protective material and the packaging material safely as potential sources of danger.

2.5. Electrical installation

Check that the data indicated on the rating plate corresponds to the voltage and frequency of the power supply.

Connect the equipment to a grounded electrical circuit!

Connect the equipment to a fixed installation. Never connect the machine to multiple plugs, T-type adapters, or extensions.

Follow the rules in force in the country where you are



At the rear of the device there is a terminal marked with the symbol that allows equipotential bonding between several devices.



3. Operating Instructions

- Before using the appliance, you should remove all the surrounding plastic wrap and clean the glue particles with non-abrasive products to avoid damaging the appliance.
- When choosing where to place the appliance, make sure it is level.
- Before connecting the appliance to the mains, make sure that the supply voltage on the rating plate corresponds to the mains voltage and check that the mains socket supports the appliance.
- Never operate the appliance with wet hands!
- Connect the appliance to a properly grounded outlet.
- Place water inside the tank up to a level near the maximum.
- Switch on the switch
- To set the temperature, turn the thermostat knob to the desired value.



During use it is normal for water to be lost by evaporation, to ensure that the water is restored, never allowing the appliance to operate below the minimum (MIN) level.

4. Cleaning

- Whenever cleaning the appliance, make sure that the power cord is disconnected from the mains and that the appliance is completely cold.
- Clean the outside of the water bath with a damp cloth and a little detergent.
- The grids and tray can be lifted in water for more effective cleaning.
- Cleaning and maintenance should not be carried out by unsupervised children..



When cleaning the appliance, do not use water jets as this may cause the appliance to reach the electrical part.



Cleaning and maintenance should not be carried out by unsupervised children.

5. Manutenção



Only qualified and accredited personnel may install and repair the equipment..



The manufacturer is not liable for damages resulting from repairs and other interventions by unqualified persons.



The installation and repair operations must comply strictly with the local and national safety regulations in force.



Only original accessories should be used for repairs.

5.1. Replacing the power cord



If the power cable is damaged, it must be replaced only by an authorized repairer or by the manufacturer..

- Cable type H07RN-F 3G 1,5 mm2..

6. WARRANTY

- The equipment is guaranteed for a period of 12 months from the date of purchase.
- The guarantee is valid against defects of origin, whether of material or of manufacture.

- Whenever there is an anomaly in the equipment, it must be returned as soon as possible, with the purchase document.
- When the warranty is triggered, damaged parts will be repaired or replaced, as the manufacturer understands. In the event of their replacement, the damaged parts become the supplier's property.
- Any defects resulting from improper installation or use / handling of the equipment are excluded from the warranty.
- The equipment will lose its warranty whenever any change / modification or even repair made by the user is identified.

PNH BY PINHA
RUA DO ALTO
VALE DO GROU – APARTADO 86
3750 - 064 AGUADA DE CIMA
TEL. +351 234 690 190
geral@pnh-bypinha.pt